

INSTRUCTION MANUAL

ALVEO3D

PrintBOX - 440 & 500 & 550

Enclosure and air filtering system for resin 3D printer - Option V2

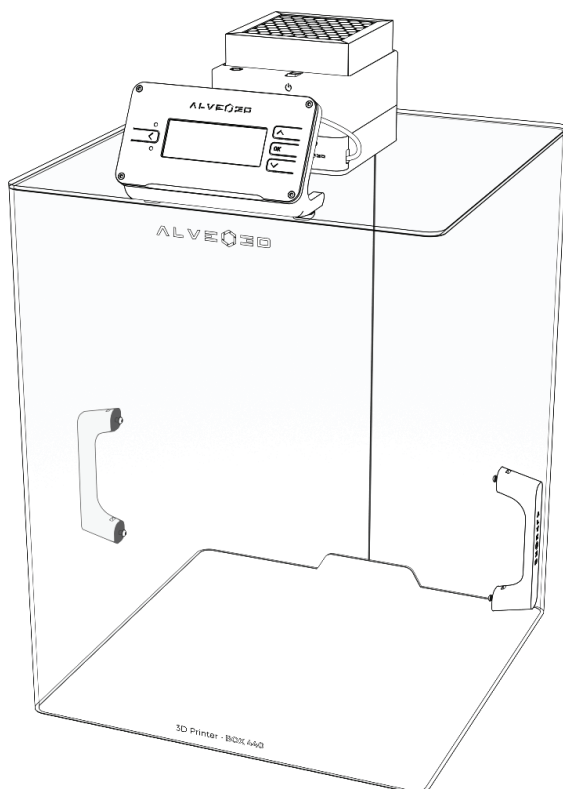

Find all assembling content on

www.alveo3d.com/assembly-printbox/

and download contents on

www.alveo3d.com/download-printbox/

SUMMARY

SUMAMRY	p. 1
SAFETY	p. 2
PROVIDED ELEMENTS	p. 3
STEP 1 - ELECTRONIC BOARD ASSEMBLING	p. 4
STEP 2 - FAN ASSEMBLING	p. 5
STEP 3 - CONNECTING FAN	p. 6
STEP 4 - CLOSING CASE	p. 7
STEP 5 - FILTERING SYSTEM AND FILTER INSTALLATION	p. 8
STEP 6 - POWER SUPPLY	p. 9
STEP 7 - HANDLES - ASSEMBLING DONE (WITHOUT OPTION V2)	p. 10
STEP 8 - OPTION V2	p. 11
STEP 9 - ASSEMBLING V2	p. 12
STEP 10 - V2 CONNECTORS	p. 13
STEP 11 - V2 WIRE CONNECTION	p. 14
STEP 12 . ONLINE SUPPORT	p. 15
NOTES	p. 16

Read the instructions before use

- The use of an enclosure helps to contain the pollutant emissions associated with the use of 3D printers. It is recommended to always use ventilation during the printing process.
- The filtration system uses a powerful fan. You should only turn it on after the device is completely assembled with the protective screw-on cover and filter. Failure to do so may result in injury.
- Please use the electrical voltages recommended during the assembly instructions to power the unit to avoid damage to the electronic components.
- Avoid contact with the electronic board during operation.
- Before each print, make sure the filter is well positioned in its casing.
- Operating range of the filter 0-60°C max
- The PrintBOX enclosure does not, under any circumstances, dispense to operate the resin 3D printer with its original cover safety.
- The PrintBOX enclosure must be placed on the flat surface.

PROVIDED ELEMENTS

Provided elements with the PrintBOX - 440 & 500 & 550

- Allen key 2 mm
- 2x Handles - PETG
- Holes cover - PETG
- AlveoZERO filtering system - 2 parts
- Electronic board V0
- Fan H6
- Filter P3DL with plastic bag
- Philips screwdriver
- Power supply 24v EU socket plug
- 4x Screw domed M4 18 mm
- 4x Nut square M4
- 8x Black self-tapping countersunk screw M5 16 mm
- 1x Black countersunk screw M3 18 mm
- 1x Nut square M3

Provided elements with Option board V2

- Electronic board V2
- Wire connection V2-V0
- Temperature sensor
- Support V2 - 3 parts
- 2x Cylindrical screw M3 25 mm
- 4x Cylindrical screw M3 12 mm
- 6x Nut Hexa M3

STEP 1 . ELECTRONIC BOARD ASSEMBLING

Slide the electronic board on the slot in the plastic casing which will be use for the filter.

Electronic board
alveoV0

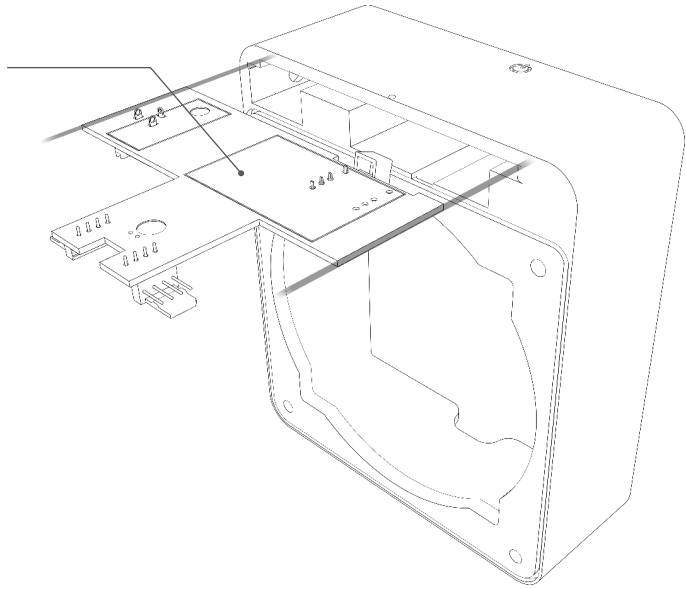

The icon  must be visible once the board is placed.

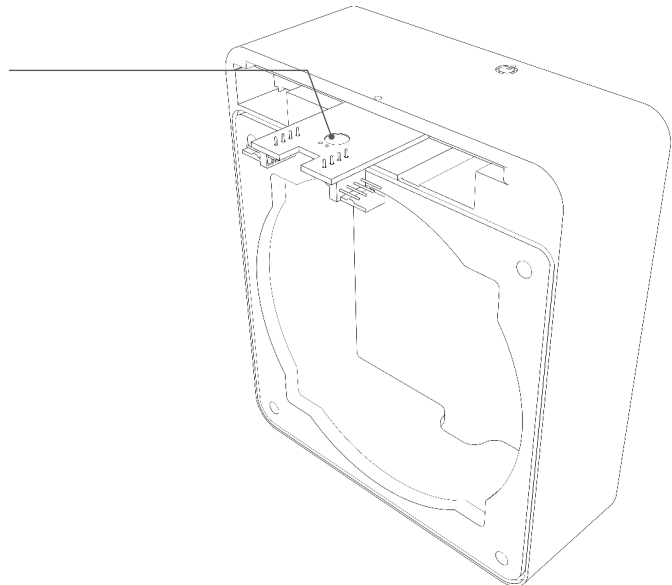

STEP 2 . FAN ASSEMBLING

- 1.** The label must be on the opposite side of the honeycomb grid. The AlveoV0 cover will be used to ease the V2 wire connection on the board AlveoV0.

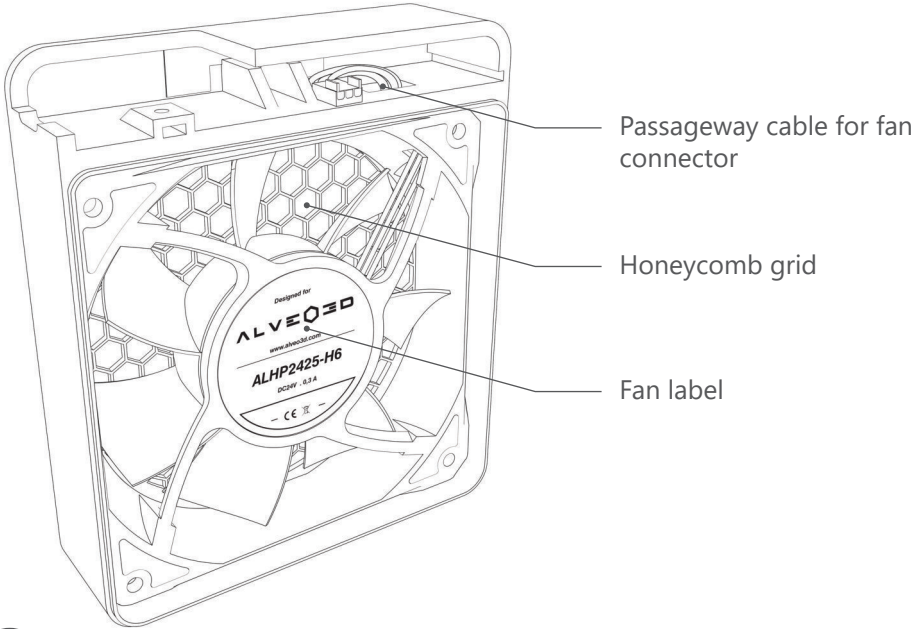

- 2.** Put the AlveoV0 cover if necessary

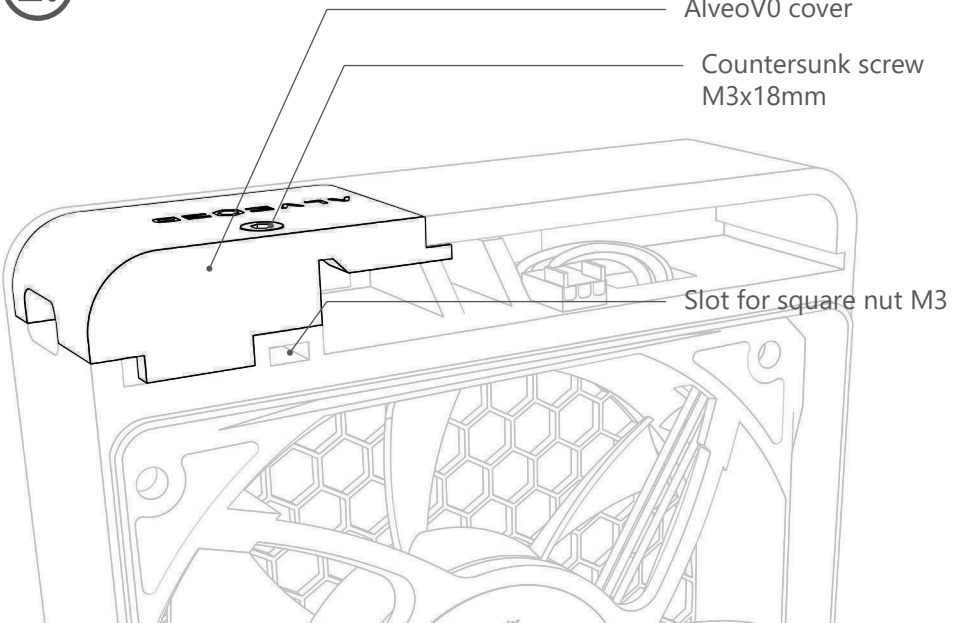

STEP 3 . CONNECTING FAN

1. To connect the fan wire to the electronic board alveoV0, the 4 pin connectors on the fan wire must be plugged to the male 4 pins connector on the same size as the power supply connector.

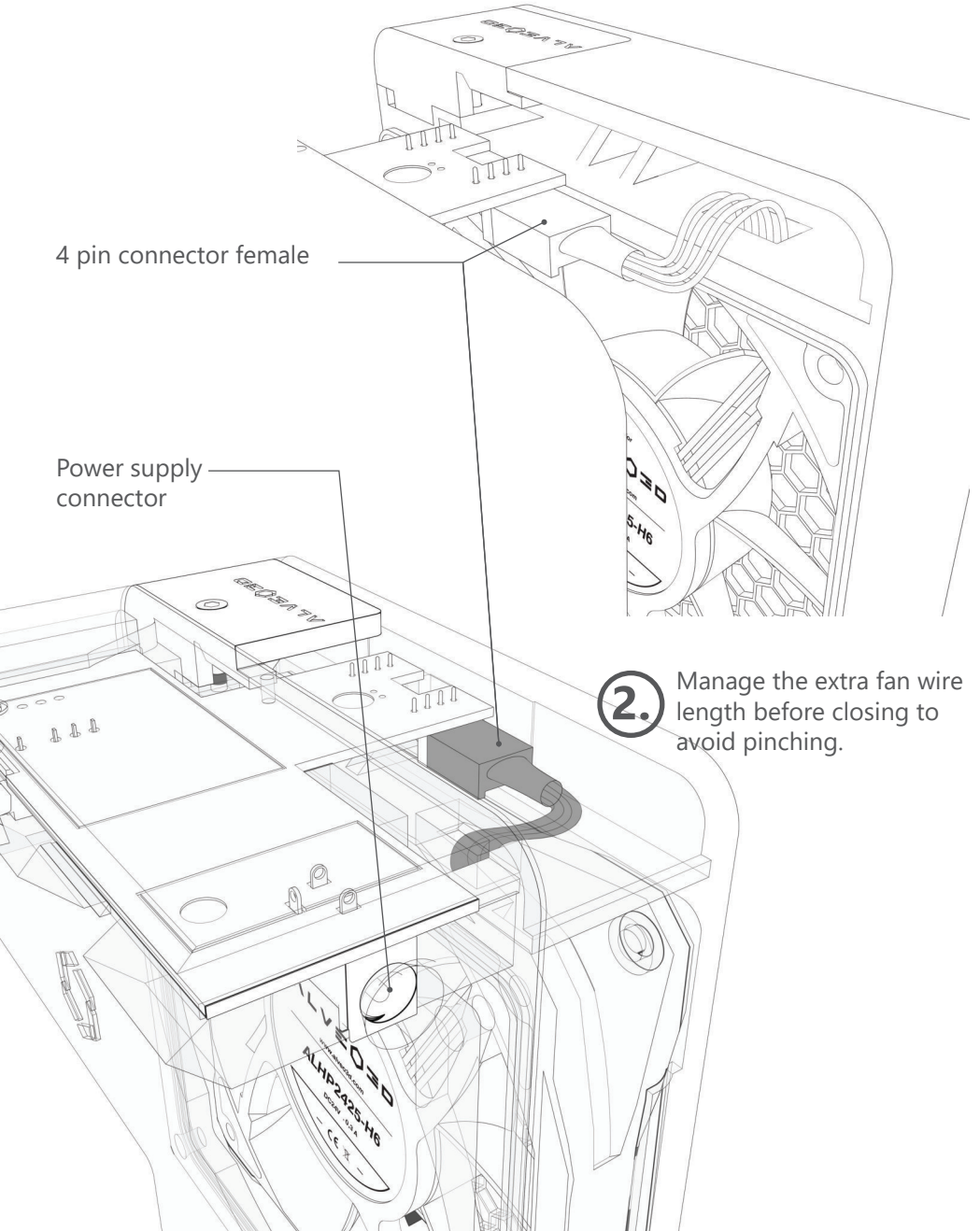

STEP 4 . CLOSING CASE

Close the filtering case by screwing the self-tapping screw from the filter slot to the fan.

During the closing, you must ensure the rail from the fan case part must perfectly fit with the rail from the filter case part to ensure a global airtight.



The head of the self-tapping screws must go a little inside the plastic (to avoid contact with the filter frame), but avoid an excessive tightening.

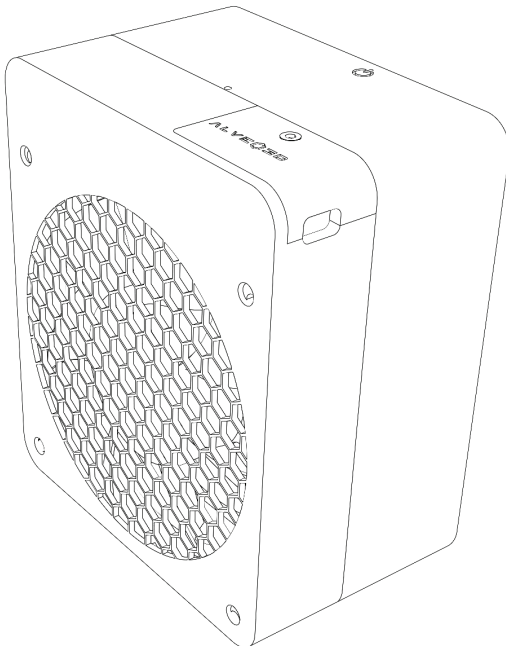
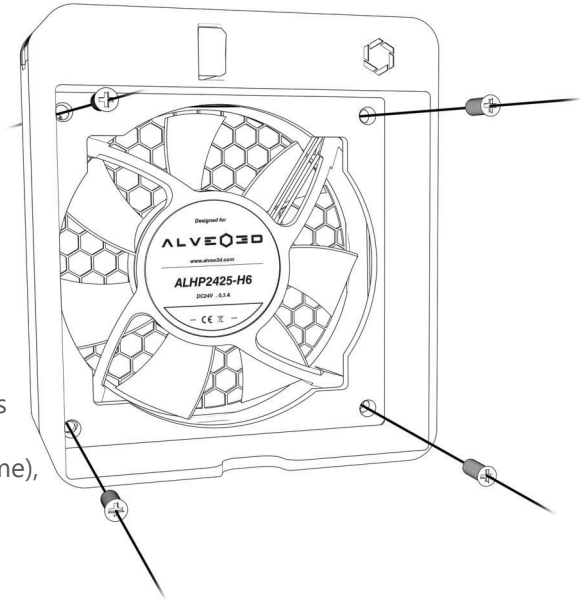

STEP 5 . FILTERING SYSTEM AND FILTER INSTALLATION

Place the filtering case on the top of the enclosure with the screwdriver, provided in the bundle. The honeycomb fan grid must be in direct contact with the top surface.

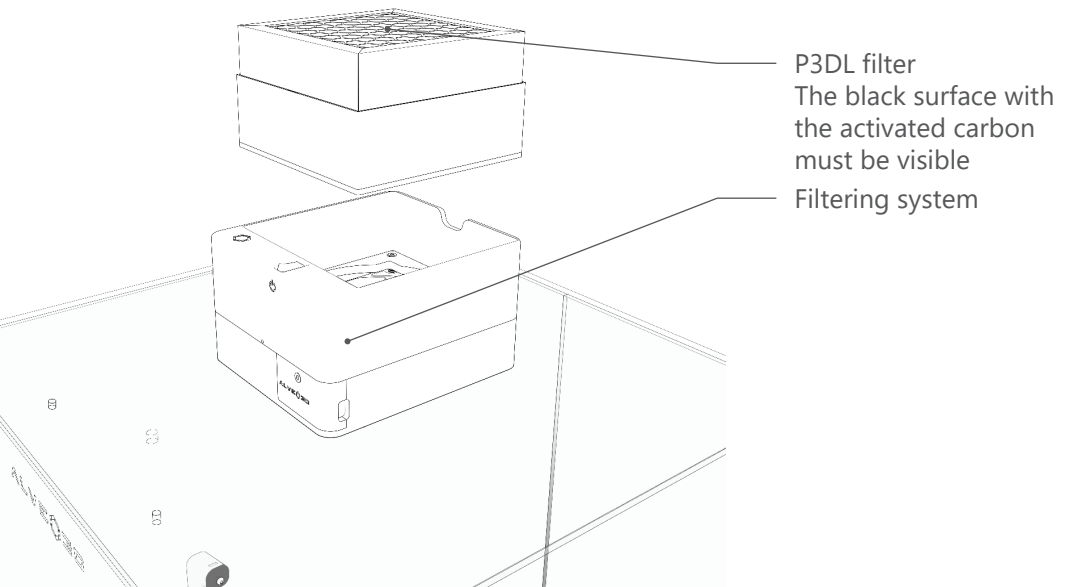
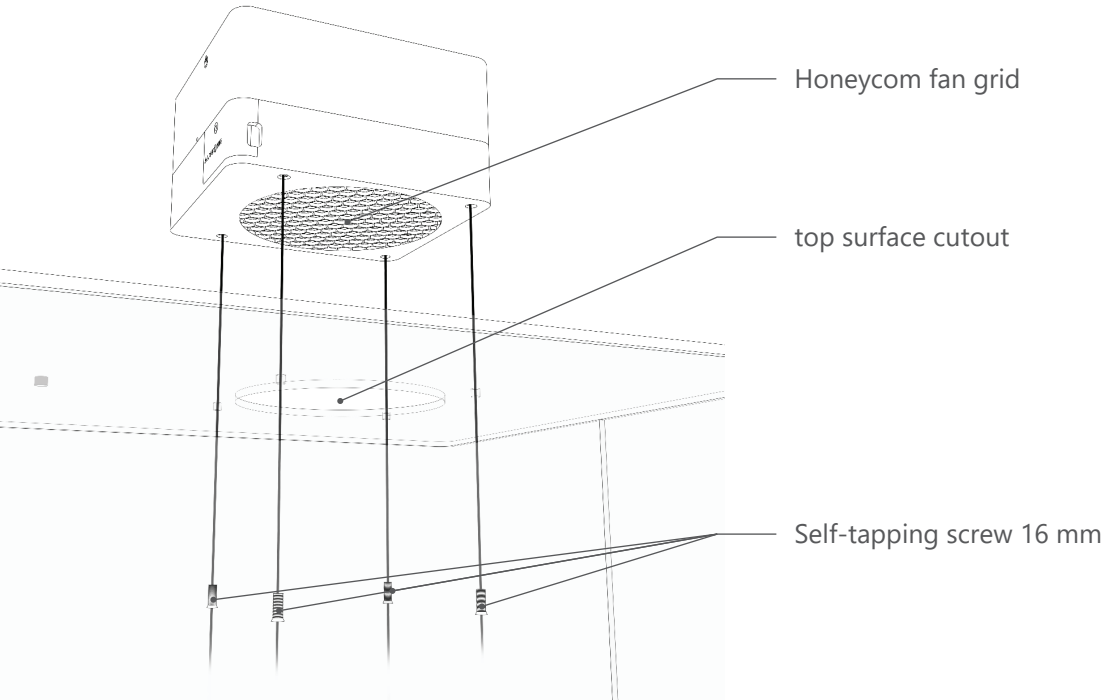

STEP 6 . POWER SUPPLY

Put the holes cover

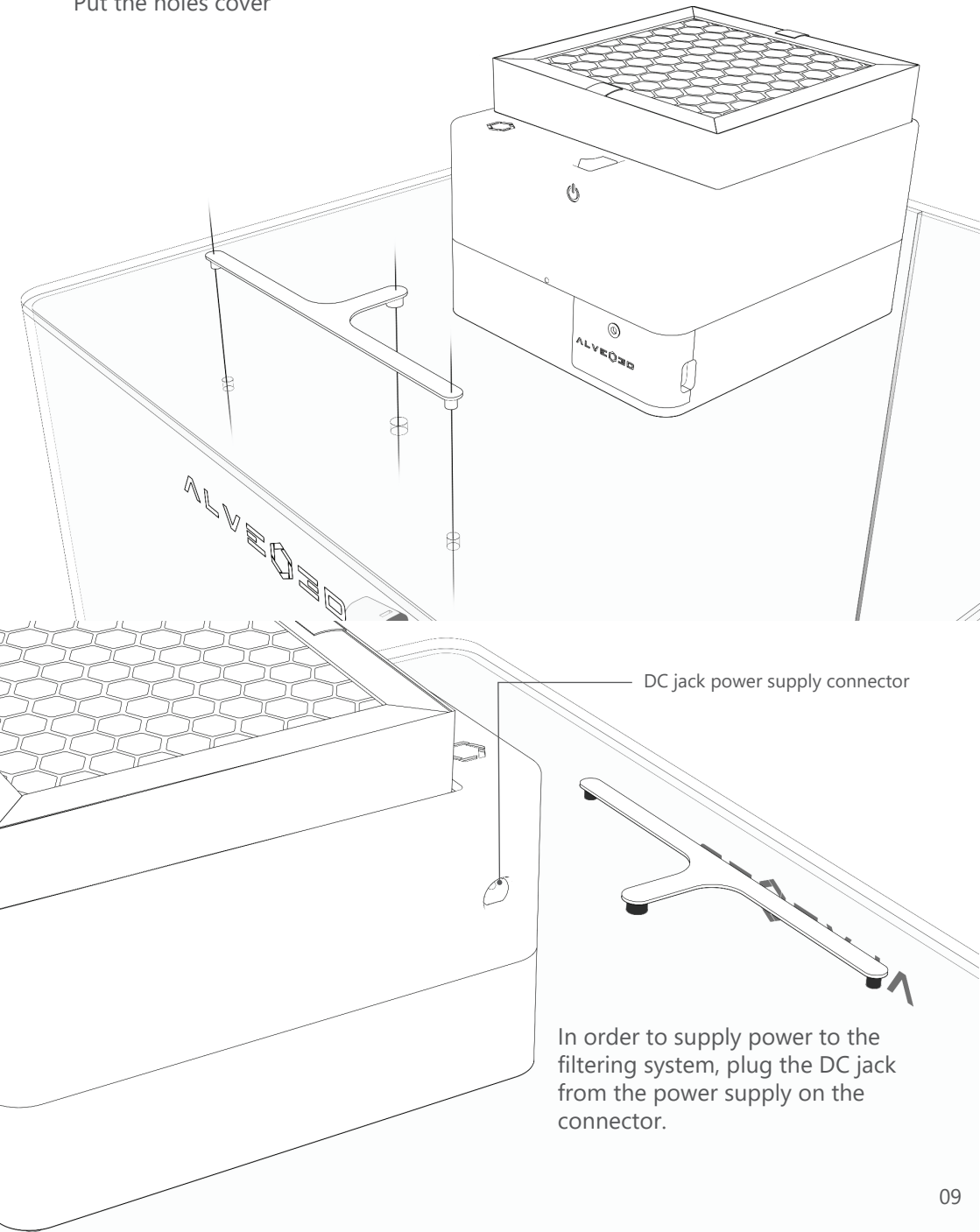

STEP 7 . HANDLES - ASSEMBLING DONE (WITHOUT OPTION V2)

Put the handles on each side of the box with the domed screw M4 18 mm. If the screwing is difficult, check if the square nuts M4 are well positioned on handles.

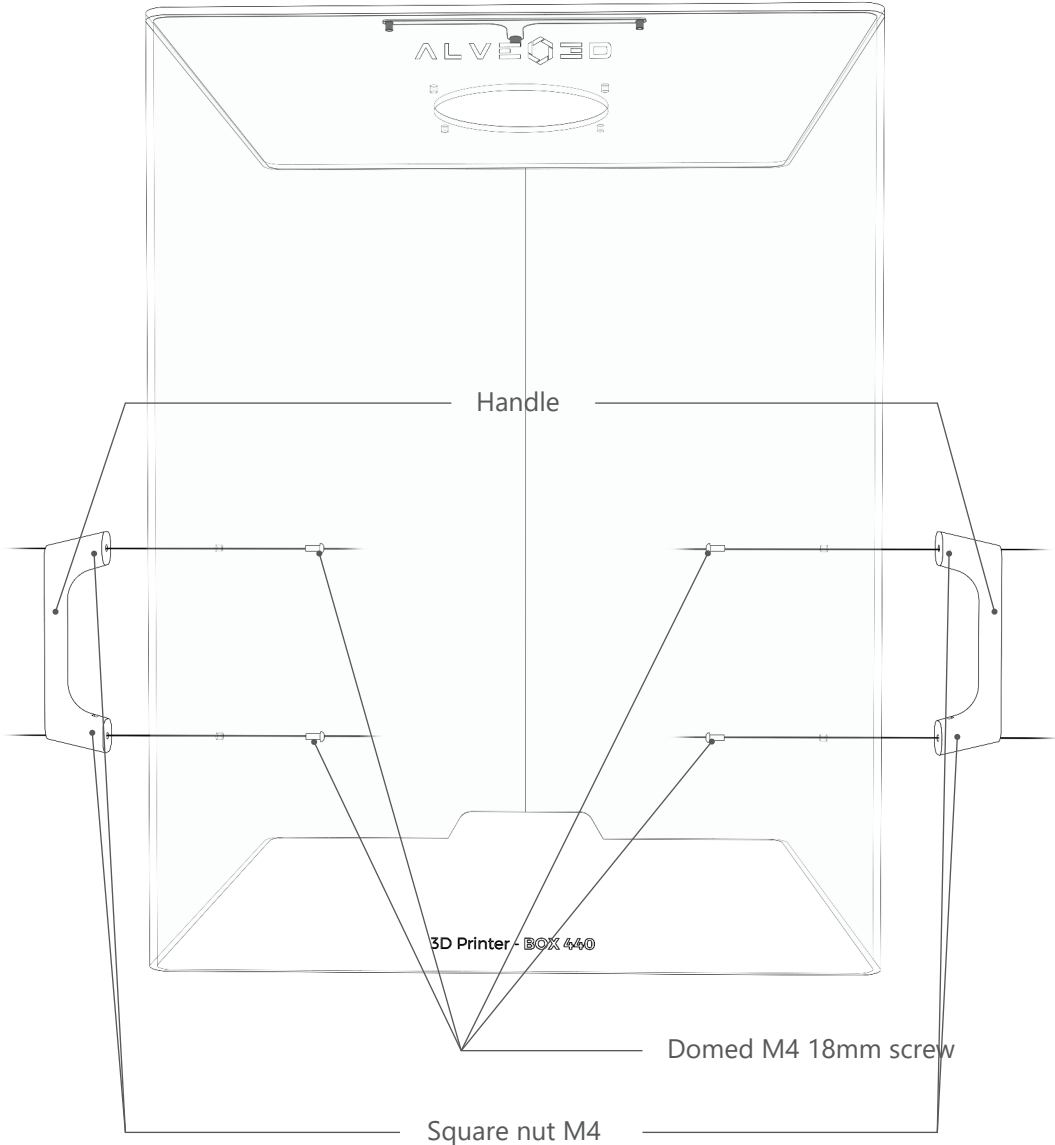

STEP 8 . OPTION V2

The filtering system can be controlled by the V2 board provided pre-assembled.

It is necessary to have the high-pressure ALHP2425-H8 fan to run the board V2.

<https://www.alveo3d.com/en/product/high-pressure-fan/>



If you order the board V2 and the high-pressure H8 fan independently of the enclosure 3D printer - BOX (PrintBOX). It is necessary to replace the provided fan ALHP2425-H6 provided with the PrintBOX by the fan ALHP2425-H8 (keep the label towards the filter).

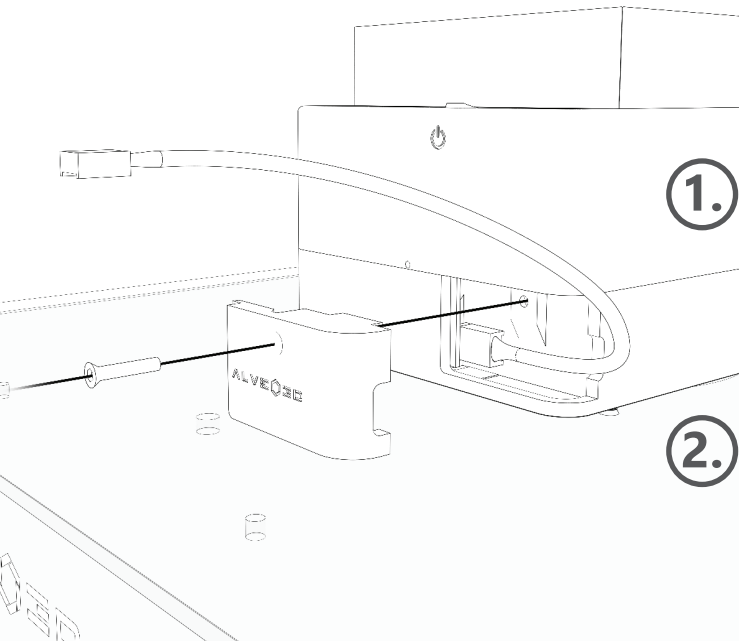

1. Unscrew the black countersunk screw M3 and gently pull the AlveoV0 cover to take it off.

2. Plug the wire to the board AlveoV0, then replace the cover back, let the wire go through the small opening, do not pinch it when tightening the screw.

STEP 9 . ASSEMBLING V2

1. Insert and screw the hexagonal nuts to mount the board V2 on the support.

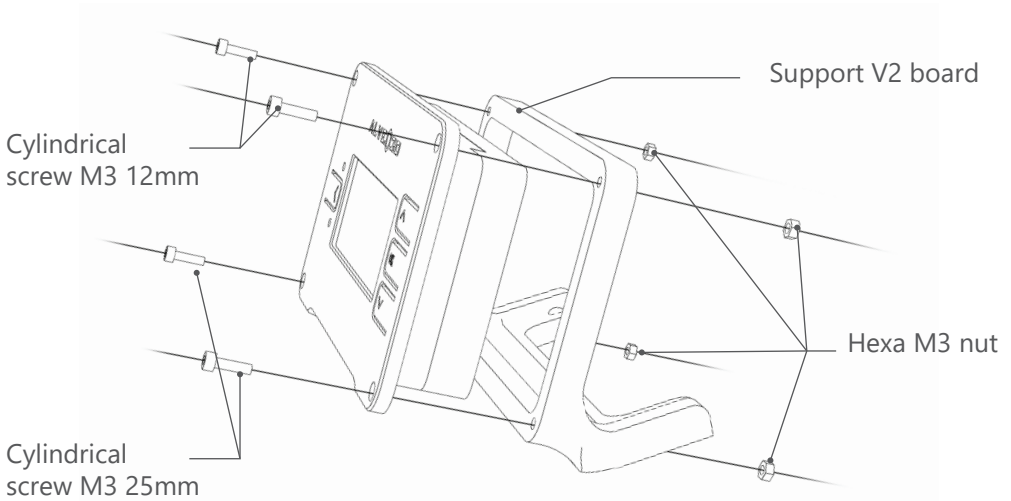

2. Mount the support and the board V2 on the enclosure with the 2 screws and printed pads.

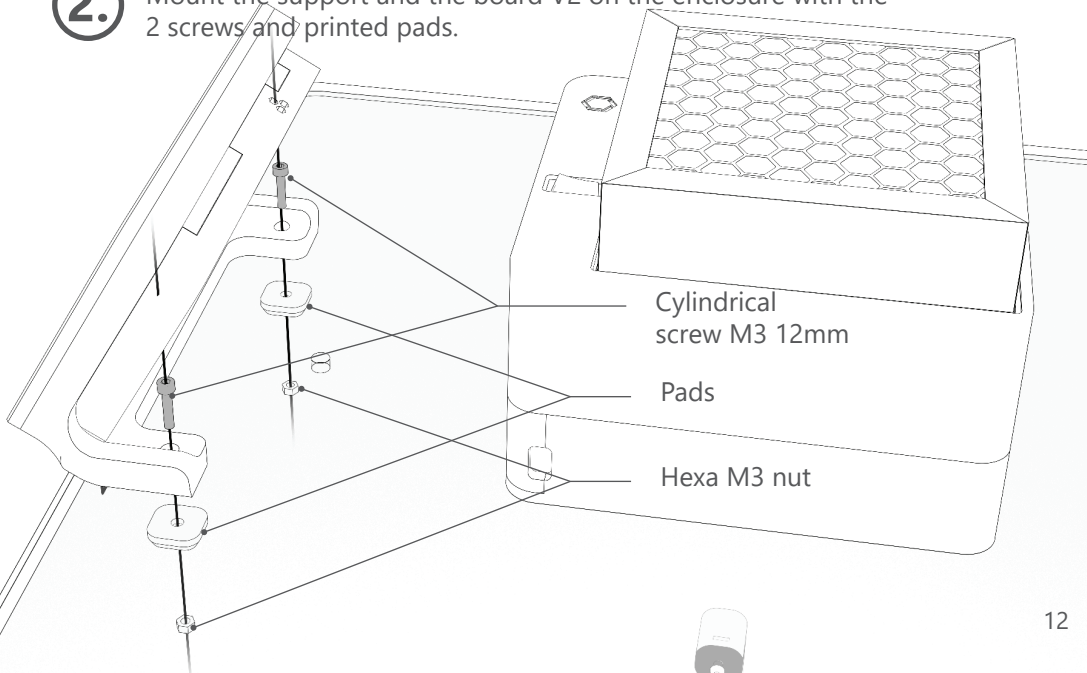

STEP 10 . V2 CONNECTORS

After the V2 is assembled on the top side of the enclosure, the last step is about to connect the cable from the step 8, linking the board AlveoV0 to the board V2 and the temperature sensor.

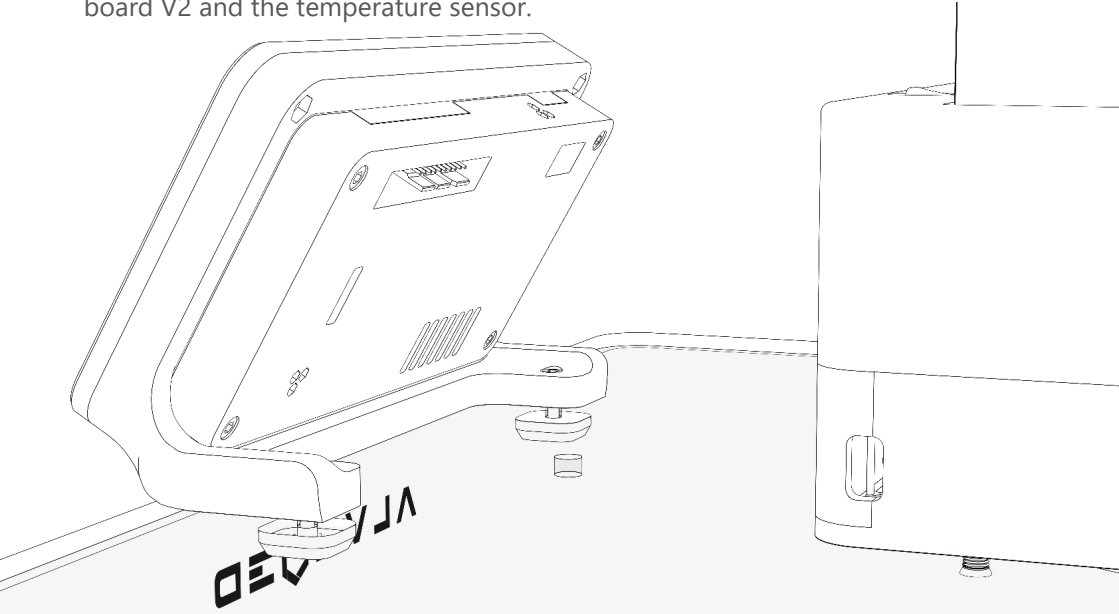

3 pins connector for the temperature sensor

4 pins connector for the V2/AlveoV0 cable

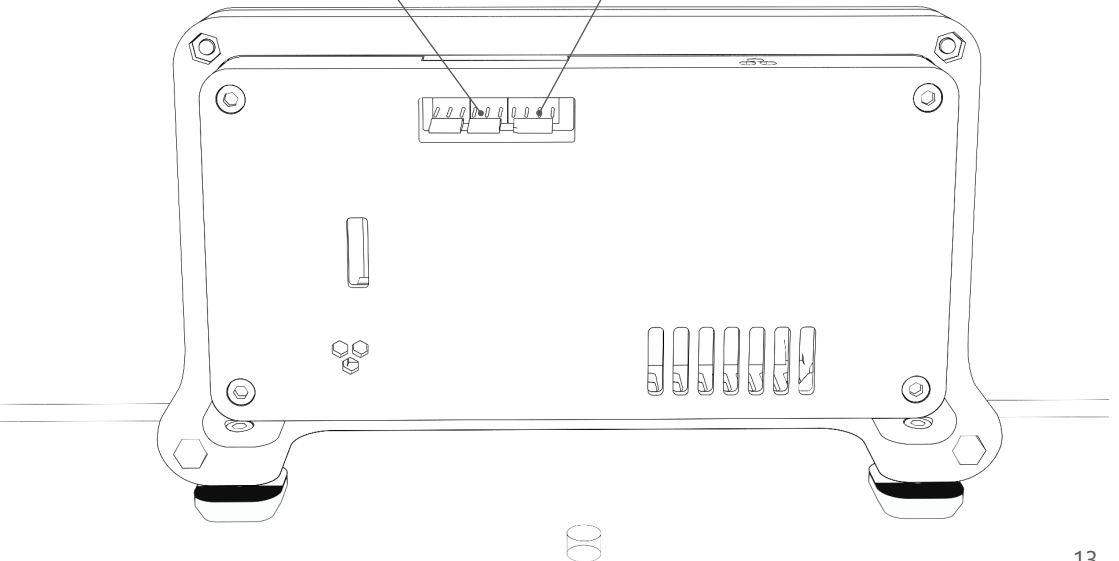

STEP 11 . V2 WIRE CONNECTION

1. Connect the power cable 4 pins from the AlveoV0 to the V2.

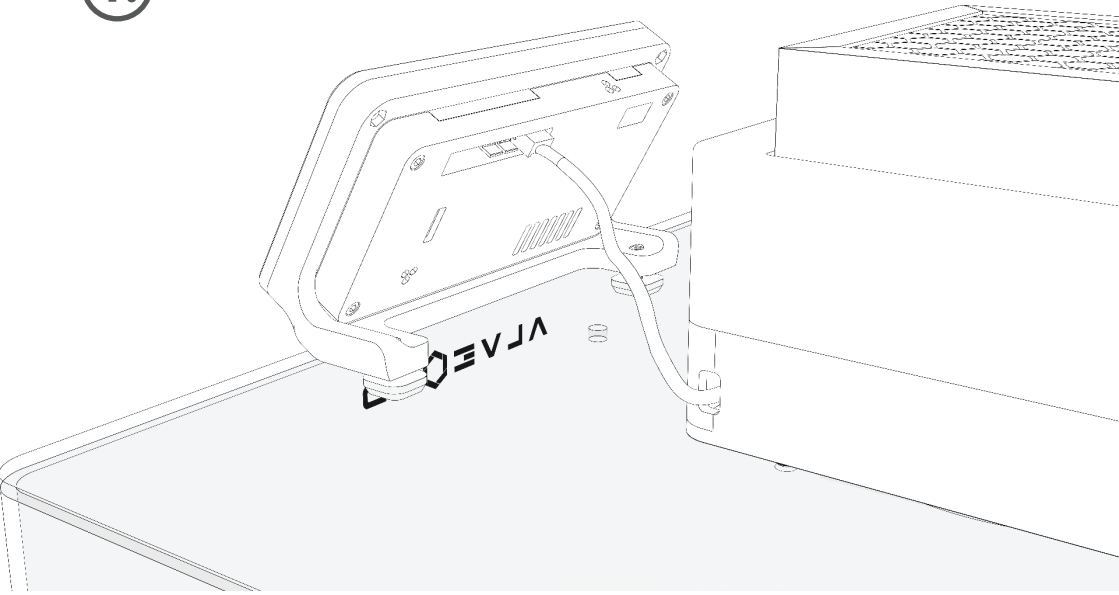

2. Plug the board V2 temperature sensor and put the metal part on the orifice behind the board V2 on the enclosure top surface.

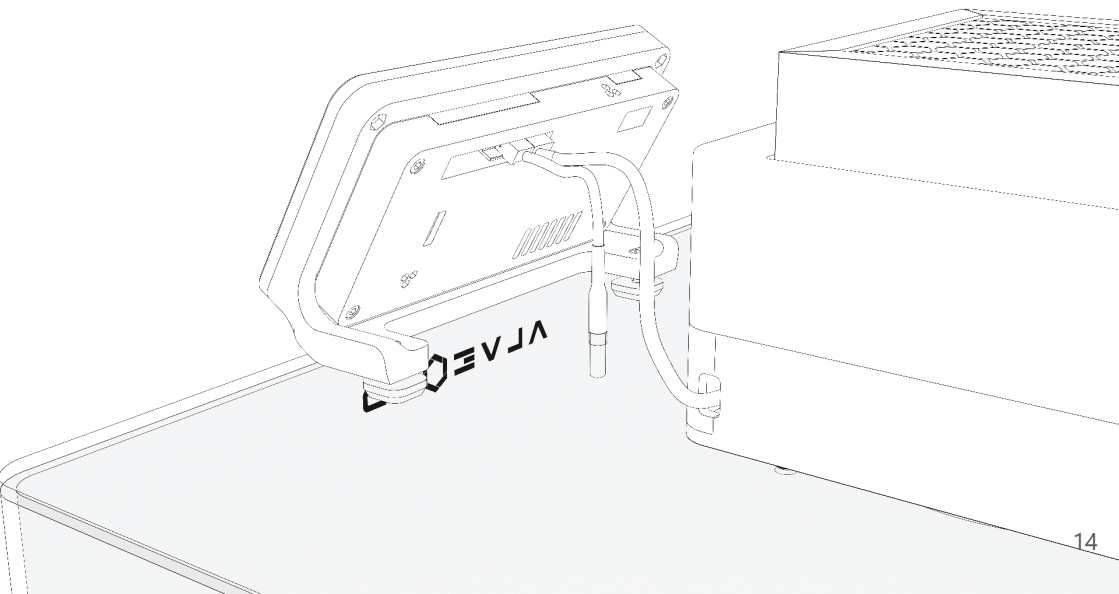

STEP 12 . ONLINE SUPPORT

For all extra information, find the online support on the following link :

<https://www.alveo3d.com/assembly-printbox/>

Find the instruction manual for the board V2 in PDF format :

<https://www.alveo3d.com/en/board-v2-assembly/>



Notice : during the initialization step of the controller board V2, the enclosure volumes are :

3D Printer - Box550 : 72 dcm³

3D Printer - Box500 : 65 dcm³

3D Printer - Box440 : 36 dcm³

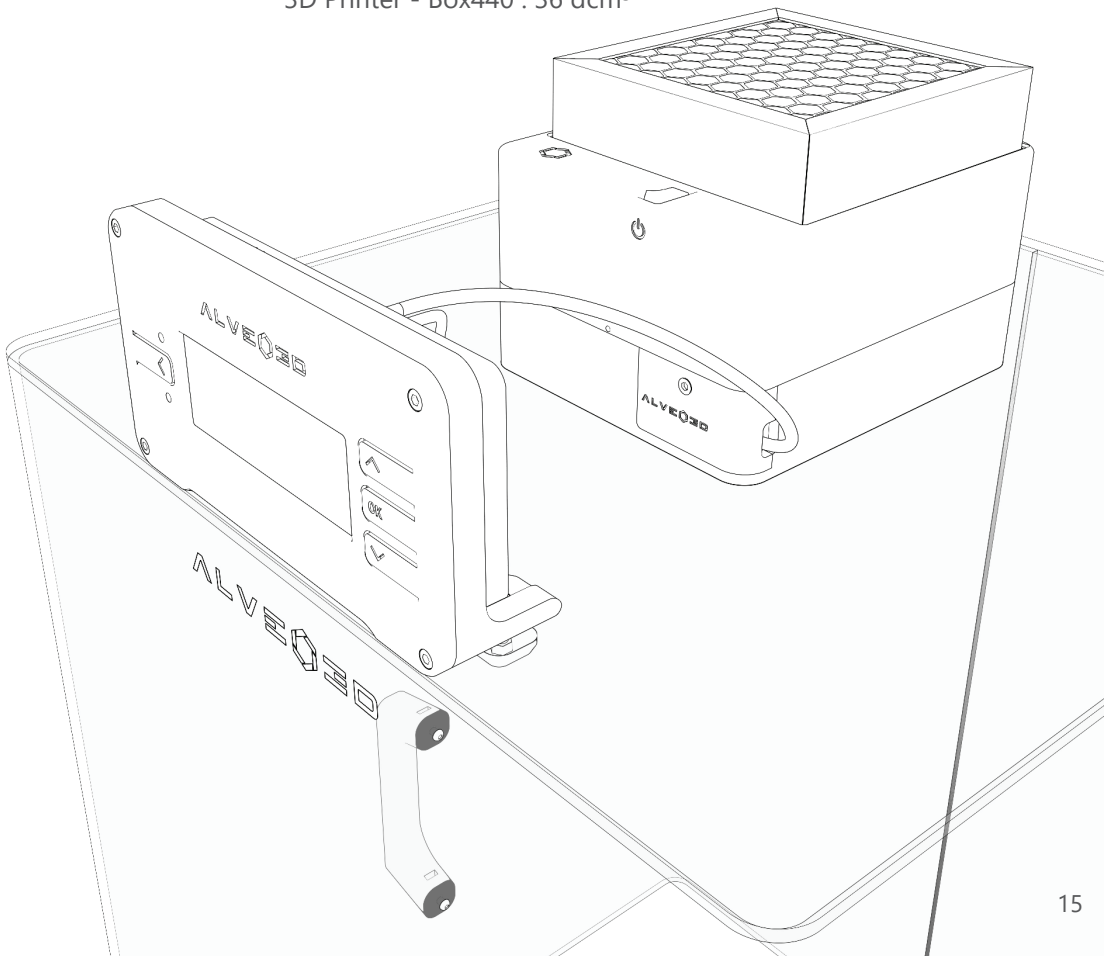

NOTES

Filter life

The life of a filter is linked to many factors such as: the type of plastic used for printing, the melting temperature, the concentration of nanoparticles and volatile organic compounds, the humidity level...

We recommend replacing the filter according to the table below :

Filter replacement	Intensive use	Occasional use
	3 months	6 months

We recommend not exceeding 600 hours of use per filter.

Filter replacement follow-up :

	Date
Filter replacement follow-up :	
Replacement 1	
Replacement 2	
Replacement 3	
Replacement 4	
Replacement 5	
Replacement 6	
Replacement 7	
Replacement 8	
Replacement 9	
Replacement 10	

NOTES :

A series of horizontal dashed lines for writing notes.

NOTES :

A series of horizontal dashed lines for writing notes.

Breath! You are filtering!



Share your experience on www.facebook.com/alveo3d/

ALVEO3D by
FLEXEE SYSTEM SAS
460 Rue de la Leyse
73000 Chambéry
www.alveo3d.com
contact@alveo3d.com

Designed, Printed & Assembled in France
